

## Configuration Table

Basic categories	
HELI transmission box	●
ZF transmission box	○
Ordinary solid tire	●
Traceless solid tire	○
Mechanical operation valve	●
Electromagnetic operation valve (proportional valve+ thumb switch)	○
Two piece valve	●
Three or four piece valve	○
Basic 3m lifting height mast	●
Other type and other height series mast	○
Standard fork	●
Non standard forks and Attachments	○
Standard color (Heli red + Grey-blue)	●
Other colors (customized)	○
Categories for Safety	
Cornering deceleration	●
Rear handle with horn for truck reversing	●
Overspeed alarm (5km/h)	○
Overspeed alarm(8km/h)	○
Overspeed alarm (10km/h)	○
Full set of OPS	●
OPS(travelling+lifting+tilting+attachment) (lowering is not included)	○
Safety switch for seat belt	○
Hydraulic valve overload protection device	●
Dry powder extinguisher (0.5kg)	○
Dry powder extinguisher (2kg)	○
Backward buzzer	●
Reversing speaker (Chinese)	○
Exclusive key	●
Universal key	○
Electronic upper buffering	●
Wide-angle central rear view mirror	●
Rearview mirror on two sides+ Center wide angle rearview mirror	○
Reverse radar (4 probes)	○
Reversing image (1 camera + 4 probes)	○

Categories for comfort	
HEAN full suspension seat	●
GRAMMER full suspension seat	○
1 USB interface (5V/1A)	●
Super low torque steering unit	●
Steering started by steering wheel	●
Steering wheel with operation ball	●
Steering wheel without operation ball	○
Fan	○
Optional overhead guard	
Overhead guard with protection net	○
Cab / Windshields	
Panel mounted cab( with fan and wiper)	○
Heater	○
Rear mounted air conditioner only for cooling	○
Rear mounted air conditioner only for cooling+heater	○
Front windshield (with wiper)	○
Rear windshield	○
Top windshield (without fan)	○
Lights	
LED rear working lamp	○
Front LED red/blue spot lamp	○
Rear LED red/blue spot lamp	○
Left, right and rear blue bar	○
Fixed type LED flicker warning lamp	●
Fixed type LED rotating warning lamp	○
Fixed type LED rotating buzzer warning lamp	○
Others	
Metric screw	●
SAE screw	○
With protective sleeves for tilting cylinder	○
With protective sleeves for steering cylinder	○
HELI FICS system	○

Note: "●" standard ; "○" optional

# CPD 25/30/35 GE2DLI



**1.1 TON 2.5-3.5t**  
G3 series Dual-drive  
Lithium Battery Forklift Truck



**ANHUI HELI CO., LTD.**

Add / No.668, FangXing Road, Hefei, China

Fax / +86-551-63639966

Tel / +86-551-63639068(America); 63639258(Europe);  
63639358(Asia); 63662105(Africa & Middle East)



LinkedIn



YouTube



Facebook





Maximum gradeability with load **20%**



Driving speed **19-20km/h**

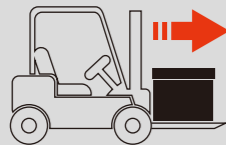

Acceleration time with load (10m) **5s**

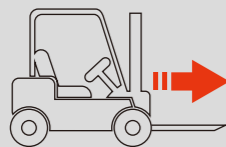

Acceleration time without load (10m) **4.5s**

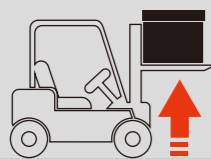

Lifting speed with load **0.44m/s**



Lifting speed without load **0.54m/s**

## Powerful Performance, High Efficiency

Front wheel dual drive motors offer stronger power and higher operation efficiency.

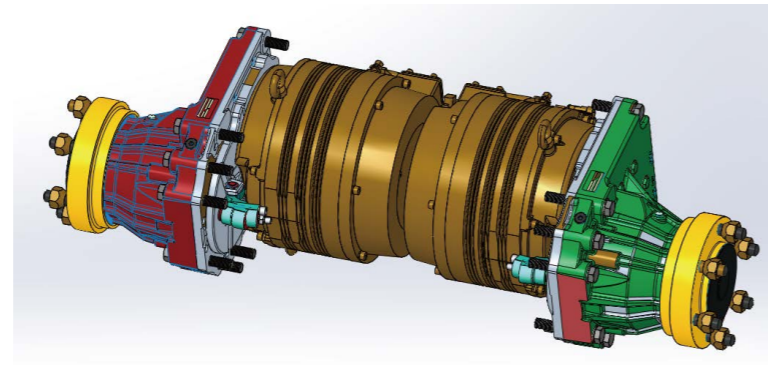

Equipped with Heli or ZF dual motor drive unit, high speed ratio reducer, high-power IP54 protection grade AC motor and oil-cooled multi disc brake, It's powerful, efficient, reliable and maintenance-free with low noise.

## Compact truck body, more flexible

Narrow truck width is more suitable for narrow aisle application; The large angle steering bridge makes the turning radius smaller, so the loading and unloading operation of narrow channel is free of pressure.



## Intelligent security, full-scope safeguards

- **Automatic cornering deceleration Truck:** Auto steering deceleration reduces the risk of turning over.
- **Steering started by steering wheel:** The steering wheel can directly start the steering function and provides the required oil quantity according to the steering wheel speed.
- **Color screen instrument:** Bilingual (CN/EN) options, full truck information at a glance.
- **Lithium battery:** Lithium battery is automatically heated at low temperature, with excellent low temperature adaptability.
- **Intelligent limit buffer:** Intelligent induction of mast lifting and lowering avoids limit impact and is safe and comfortable.
- **Intelligent operation protection:** A full set of OPS system can avoid misoperation and ensure safety.
- **Intelligent control strategy:** Dual core controller is in line with the latest EU safety requirements.
- **Battery box locking perception:** The battery box is not locked and the vehicle does not start, so as to avoid safety accidents caused by careless operation.

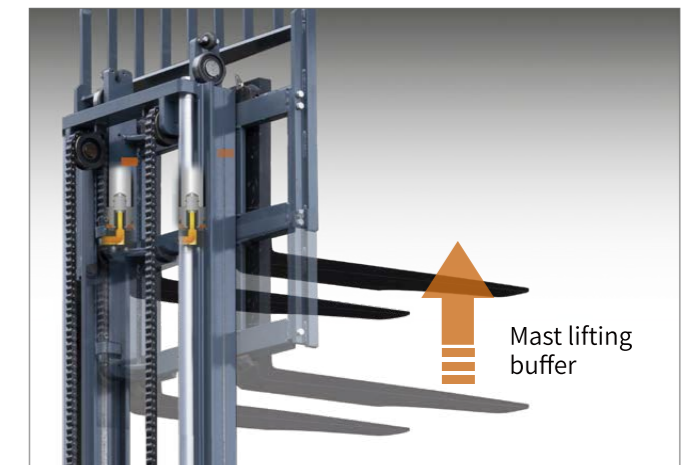
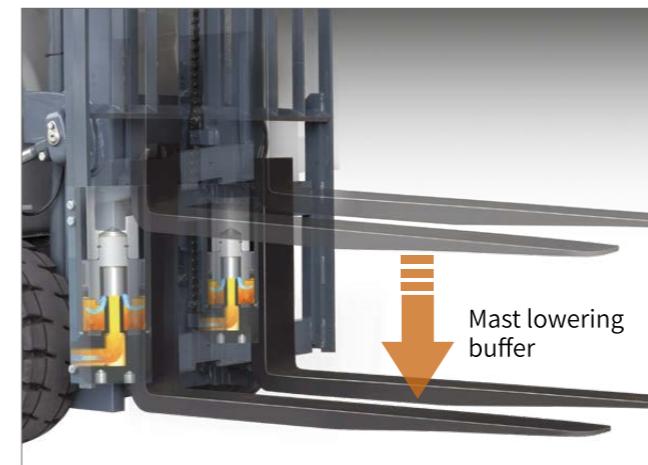
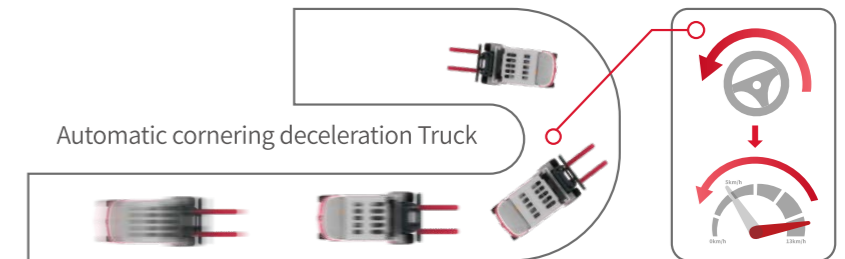

### HELI smart fleet management system

Vehicle positioning	Statistical form
Remote diagnosis	Vehicle management
Remote monitoring	Identification recognition (optional)
Maintenance reminder	Weight management (optional)
Battery management	Collision management (optional)

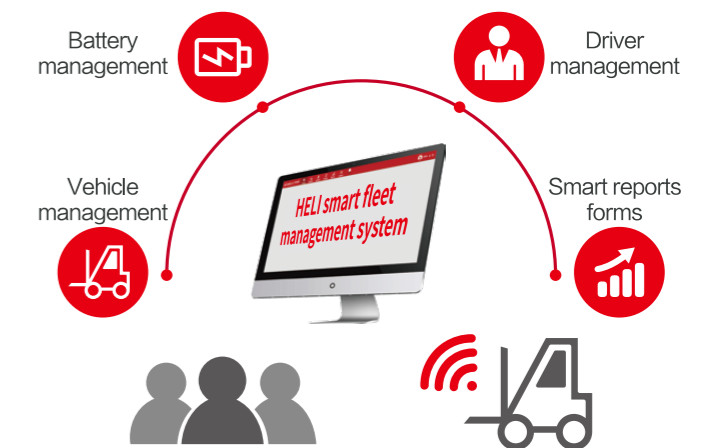

Note: the data displayed are all based on the model 3.5t, and data for other trucks are shown in the table of technical parameters.

# Optimized Ergonomic Design, Better Driving Comfort



Right positioned control valve is more comfortable.

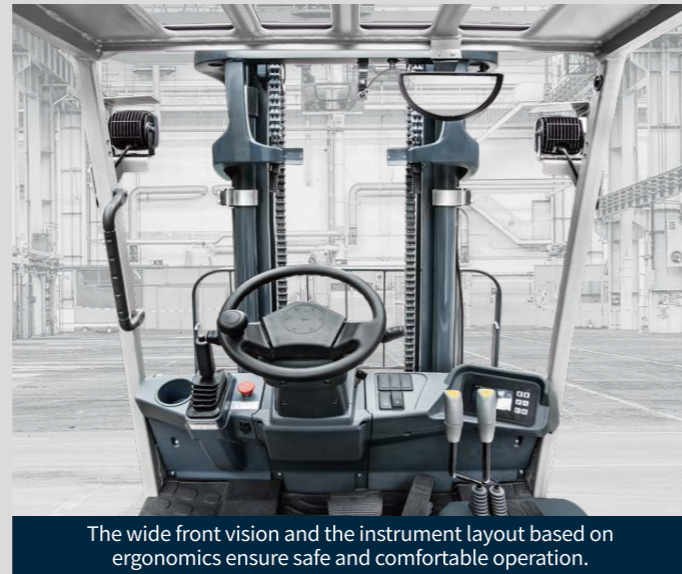

The wide front vision and the instrument layout based on ergonomics ensure safe and comfortable operation.



Enlarged boarding space and foot operation space offer more comfortable operation.



The rear handle and warning horn are designed for safer reversing operation.



Grammer full suspension seat is optional for more comfortable driving. The multifunctional armrest integrates fingertip switch, direction switch, steering switch, PES gear, horn button, emergency power-off switch, etc., to realize convenient operation and precise control of electromagnetic proportion.



Stamped integral overhead guard with transparent rainproof cover ensures operation in rainy days.



- USB power supply design is more thoughtful.
- Newtype of ratchet hand brake reduces operating force by 17%.
- PES Three-speed mode: Choose multiple speed modes according to working conditions, guarantee work efficiency.

20%

# High Quality & High Reliability

Reinforced casting drive axle housing and steering axle body, optimized design of mast system, has passed durability test which has reliable quality to ensure operation safety.

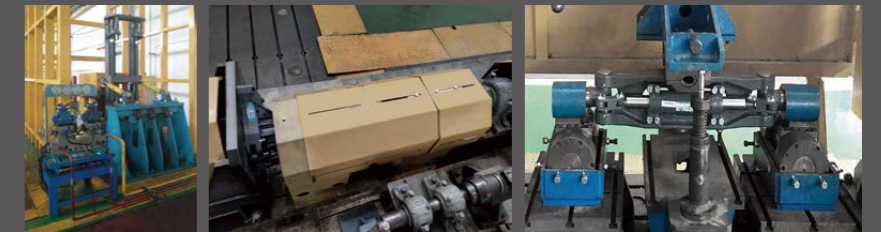

# Tested in Rough Operating Environment



The truck passed simulation experiment of bumpy road.



IPX4 waterproof: the vehicle is powered on to simulate a 15min short-time 5000L rainstorm test, and the vehicle can continue to run without failures.

# Centralized Checkpoints, Easy Maintenance



- The electrical design is concentrated on the top of counterweight, which is reliable for heat dissipation and convenient for inspection and maintenance.
- Side battery is easy to replace and maintain.

### Manufacturer and Technical Data

Characteristics					
1.01	Manufacturer			<b>HELI</b>	
1.02	Model		CPD25	CPD30	CPD35
1.03	Configuration number		GE2DLI*	GE2DLI*	GE2DLI*
1.04	Rated capacity	Q	kg	2500	3000
1.05	Load center distance	c	mm	500	500
1.06	Power mode			Lithium battery	
1.07	Driving mode			Seated	
1.08	Load distance, center of drive axle to fork	x	mm	474	485
1.09	Wheelbase	y	mm	1615	1615
Weight					
2.01	Total weight (with/without battery)		kg	4360/4075	4905/4525
2.02	Axle load (laden,front/rear)		kg	6061/799	6982/922
2.03	Axle load (unladen,front/rear)		kg	2014/2346	2139/2766
Tyres					
3.01	Tyre type			SE	
3.02	Tyre size, front			23x9-10	23x10-12
3.03	Tyre size, rear			18x7-8	200/50-10
3.04	Wheels, number front/rear (x=driven wheels)			2x/2	2x/2
3.05	Tread, front	b10	mm	990	975
3.06	Tread, rear	b11	mm	1000	990
Dimensions					
4.01	Mast tilt angle (forward/backward)	$\alpha/\beta$	°	6/8	6/8
4.02	Height (mast lowered)	h1	mm	2155	2155
4.03	Free lifting height	h2	mm	140	145
4.04	Lifting height (standard)	h3	mm	3000	3000
4.05	Max. height, extended	h4	mm	4030	4217
4.06	Height of overhead guard	h6	mm	2260	2260
4.07	Height of seat	h7	mm	1260	1260
4.08	Towing coupling height	h10	mm	395	395
4.09	Overall length (with fork)	l1	mm	3495	3540
4.10	Overall length (without fork)	l2	mm	2425	2470
4.11	Overall width	b1	mm	1195/1197	1195/1222
4.12	Fork carriage, DIN standard			2A	3A
4.13	Fork size: thickness x width x length	s/e/l	mm	40/122/1070	45/125/1070
4.14	Distance between fork-arms, Max./Min.	b5	mm	1060/250	1060/250
4.15	Ground clearance (laden,between mast)	m1	mm	105	105
4.16	Ground clearance (center of wheelbase)	m2	mm	135	135
4.17	Right angle stacker aisle width for pallet 1000 x1200mm crossways	Ast	mm	3715	3760
4.18	Right angle stacker aisle width for pallet 800 x1200mm lengthways	Ast	mm	3900	3940
4.19	Min. outside turning radius	Wa	mm	2024	2057
Performance Data					
5.01	Travel speed (laden/unladen)		km/h	20/20	19/20
5.02	Lift speed (laden/unladen)		m/s	0.5/0.60	0.5/0.60
5.03	Lowering speed (laden/unladen)		m/s	0.58/0.53	0.55/0.45
5.04	Max.drawbar pull (laden/unladen)		N	23000/15000	27000/17000
5.05	Max.gradeability (laden/unladen)		%	25/29	21/29
5.06	Acceleration time (10 m)(laden/unladen)		s	5.2/5	4.8/4.4
Lithium Battery					
6.01	Lithium battery voltage/Capacity		V/Ah	80/280	80/404
6.02	Lithium battery weight (Min./Max.)		kg	285/485	380/485
Motor and Controller					
7.01	Driving motor powering (S2-60min)		kW	10X2	10X2
7.02	Lifting motor powering (S3-15%)		kW	26	26
7.03	Driving motor controlling mode			MOSFET/AC	
7.04	Lifting motor controlling mode			MOSFET/AC	
Other Information					
8.01	Service brake/ Parking brake			Hydraulic/Mechanical	
8.02	Operating pressure for attachments		Mpa	16	16

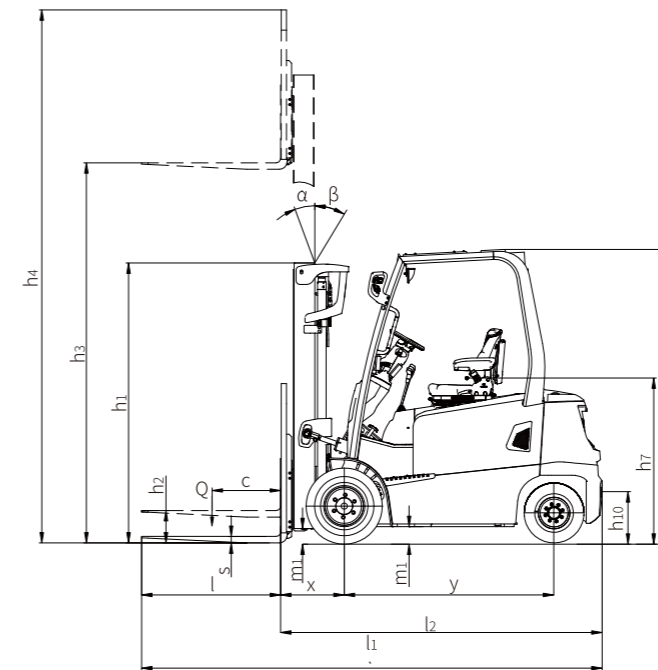

Ast : Right angle stacking aisle width  
a : Clearance 200mm  
l6 : Load length  
b12 : Load width

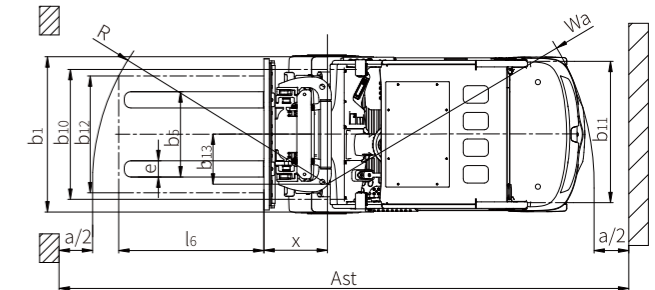

### Load curve

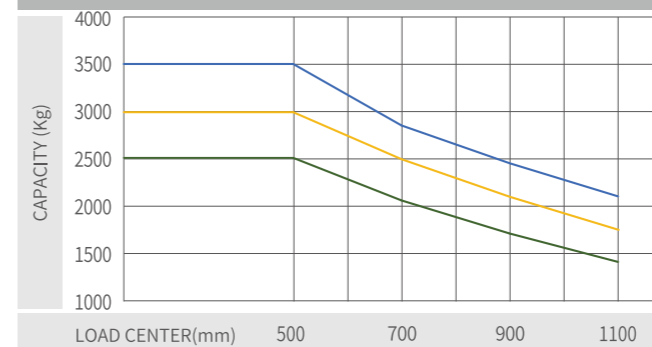

— 3.5t  
— 3.0t  
— 2.5t

**Note:** The vertical axis stands for load capacity while the horizontal axis stands for load center which is calculated from the front surface of the forks to the gravity of the standard load. The standard load means a cubic with 1000mm edge length. When the mast is tilted forward, the worker using nonstandard forks for loading large goods, the load capacity will be reduced. The load capacity of standard mast at different load center can be known from this load chart.

### Lithium battery

Lithium battery brand	HELI				CATL					
	80V/280Ah	80V/404Ah*	80V/560Ah	80V/606Ah	80V/271Ah	80V/302Ah*	80V/404Ah	80V/456Ah*	80V/542Ah	80V/604Ah*
2.5t	●	○	○	○	○	○	○	○	○	○
3.0t	—	●	○	○	—	—	○	○	○	○
3.5t	—	●	○	○	—	—	○	○	○	○
Lithium battery heating in low temperature	●									
Note	●: standard ○: optional —: not applicable									

### Charger

Charger model		D80V200ALi-123 (Single module) / D80V200ALi-423 (Single module)	D80V100ALi-125 (Single module) / D80V100ALi-425 (Single module)
Suitable battery model		48 / 80V lithium battery, recommended capacity greater than 240Ah	48 / 80V lithium battery, recommended capacity less than 240Ah
Wiring connection		Three-phase four-wire system	
Charger power	KVA	22	10
Air-switch model of higher-up power	A	63	32
Input voltage range	Vac	380±15%	
Input current	A	<40	<20
Output current	A	0~200	0~100
Protection degree		(Use indoors)	
Working environment temperature	°C	-20~ +45	
Power connections		National standard charging gun	
Charger		Full charge time = required charging capacity of lithium battery / charging current + 0.2 hours For example: the standard battery capacity of 3T lithium battery forklift is 80V / 404ah. If the lithium battery capacity has been consumed to the instrument alarm and charged with a 200A charger, the full charge time is 404 * 0.9 / 200 + 0.2 hours = about 2 hours.	

**WIDE VIEW 2-STAGE MAST**

Mast model	Max lifting height (mm)	Load capacity (lode center 500mm) (kg)			Mast overall height (mm)			Free lifting height (with backrest) (mm)			Service weight (kg)			Mast tilt angle α/β(°)
		2.5t	3t	3.5t	2.5t	3t	3.5t	2.5t	3t	3.5t	2.5t	3t	3.5t	
M200	2000	2500	3000	3500	1655	1655	1655	140	145	150	4252	4797	5192	6/8
M250	2500	2500	3000	3500	1905	1905	1905	140	145	150	4310	4855	5250	6/8
M270	2700	2500	3000	3500	2005	2005	2005	140	145	150	4325	4870	5265	6/8
M300	3000	2500	3000	3500	2155	2155	2155	140	145	150	4360	4905	5300	6/8
M330	3300	2500	3000	3500	2305	2305	2305	140	145	150	4391	4936	5331	6/8
M350	3500	2500	3000	3500	2405	2405	2405	140	145	150	4396	4941	5336	6/8
M370	3700	2500	3000	3500	2505	2505	2505	140	145	150	4398	4943	5338	6/5
M400	4000	2500	3000	3500	2705	2705	2705	140	145	150	4498	5043	5438	6/5
M425	4250	2500	2900	3350	2830	2830	2830	140	145	150	4511	5066	5461	6/5
M450	4500	2400	2800	3200	2955	2955	2955	140	145	150	4545	5090	5485	6/5
M475	4750	2300	2600	3150	3180	3180	3180	140	145	150	4569	5114	5509	6/5
M500	5000	2100	2500	2900	3205	3205	3205	140	145	150	4589	5138	5533	6/5
M550	5500	1500	2250	2350	3505	3505	3505	140	145	150	4686	5233	5628	3/5
M600	6000	1200	1550	1650	3755	3755	3755	140	145	150	4732	5279	5674	3/5

**WIDE VIEW FULL FREE 2-STAGE MAST**

Mast model	Max lifting height (mm)	Load capacity (lode center 500mm) (kg)			Mast overall height (mm)			Free lifting height (with backrest) (mm)			Service weight (kg)			Mast tilt angle α/β(°)
		2.5t	3t	3.5t	2.5t	3t	3.5t	2.5t	3t	3.5t	2.5t	3t	3.5t	
ZM200	2000	2500	3000	3500	1655	1655	1655	640	470	475	4256	4811	5206	6/8
ZM250	2500	2500	3000	3500	1905	1905	1905	890	720	725	4322	4877	5272	6/8
ZM270	2700	2500	3000	3500	2005	2005	2005	990	820	825	4344	4899	5294	6/8
ZM300	3000	2500	3000	3500	2155	2155	2155	1140	970	975	4370	4925	5320	6/8
ZM330	3300	2500	3000	3500	2305	2305	2305	1290	1120	1125	4401	4956	5351	6/8
ZM350	3500	2500	3000	3500	2405	2405	2405	1390	1220	1225	4408	4963	5358	6/8
ZM370	3700	2500	3000	3500	2505	2505	2505	1490	1320	1325	4414	4969	5364	6/5
ZM400	4000	2500	3000	3500	2705	2705	2705	1690	1520	1525	4548	5073	5468	6/5
ZM425	4250	2500	2900	3350	2830	2830	2830	1815	1645	1650	4556	5091	5486	6/5
ZM450	4500	2400	2800	3200	2955	2955	2955	1940	1770	1775	4562	5117	5512	6/5
ZM475	4750	2300	2600	3150	3180	3180	3180	2165	1995	2000	4578	5133	5528	6/5
ZM500	5000	2100	2500	2900	3205	3205	3205	2190	2020	2025	4603	5158	5553	6/5
ZM550	5500	1500	2250	2350	3505	3505	3505	2490	2320	2325	4681	5244	5638	3/5
ZM600	6000	1200	1550	1650	3755	3755	3755	2740	2570	2575	4712	5267	5662	3/5

NOTE: (1)2.5t, free lifting height 370 mm increased without backrest.  
(2)3-3.5t, free lifting height 396 mm increased without backrest.

**WIDE VIEW FULL FREE 3-STAGE MAST**

Mast model	Max lifting height (mm)	Load capacity (lode center 500mm) (kg)			Mast overall height (mm)			Free lifting height (with backrest) (mm)			Service weight (kg)			Mast tilt angle α/β(°)
		2.5t	3t	3.5t	2.5t	3t	3.5t	2.5t	3t	3.5t	2.5t	3t	3.5t	
ZSM360	3600	2500	3000	3500	1895	1895	1895	880	710	715	4436	5002	5397	6/5
ZSM400	4000	2500	3000	3500	2030	2030	2030	1015	845	850	4471	5039	5434	6/5
ZSM435	4350	2400	2900	3250	2145	2145	2145	1130	960	965	4501	5076	5471	6/5
ZSM450	4500	2300	2750	3050	2195	2195	2195	1180	1010	1015	4511	5091	5486	6/5
ZSM470	4700	2250	2600	2950	2245	2245	2245	1230	1060	1065	4516	5096	5491	6/5
ZSM480	4800	2200	2550	2900	2295	2295	2295	1280	1110	1115	4556	5122	5517	6/5
ZSM500	5000	2050	2400	2750	2355	2355	2355	1340	1170	1175	4576	5150	5545	6/5
ZSM540	5400	1500	2150	2300	2505	2505	2505	1490	1320	1325	4616	5187	5582	3/5
ZSM600	6000	1100	1500	1650	2720	2720	2720	1705	1535	1540	4716	5291	5686	3/5
ZSM650	6500	950	1300	1400	2905	2905	2905	1990	1720	1725	4781	5347	5742	3/3
ZSM700	7000	850	1100	1200	3155	3155	3155	2140	1970	1975	4876	5439	5834	3/3

NOTE: (1)2.5t, free lifting height 350 mm increased without backrest.  
(2)3-3.5t, free lifting height 400 mm increased without backrest.

# Operating Cost Comparison: Lithium battery forklift **VS.** Lead-acid battery forklift **VS.** IC forklift

The advantages of HELI lithium battery forklift trucks are more prominent in the life cycle cost.

Compared with internal combustion forklift truck, lithium battery forklift truck has the advantages of no noise, no pollution, small vibration and simple operation.

Compared with the lead-acid battery forklift truck, lithium battery forklift has the characteristics of fast charging and charging at any time, which is more suitable for multi shift operation.

Besides, HELI lithium battery forklift is maintenance free, high power conversion efficiency, and economical overall operation cost.

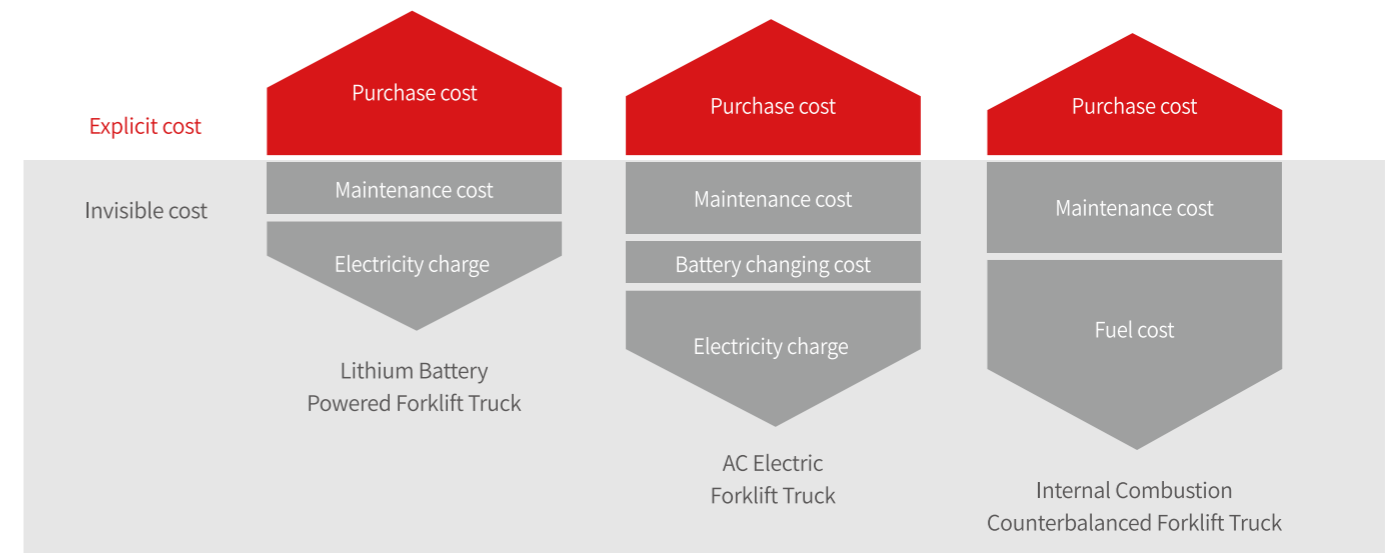

**Lithium Battery Advantages**



- The truck selects mature and economical square iron phosphate lithium battery core and module used by large numbers of commercial vehicles;
- The module adopts aluminum alloy plate frame, which is firm, light in weight and has good heat dissipation effect;
- Fast charging: fast charging makes truck gapless operation possible, and it can be fully charged in up to one hour;
- High efficiency and safety: The charging and discharging efficiency is up to 98%, and temperature of thermal runaway is over 600 °C;
- Low temperature adaptability: Standard configuration of heating function ensures normal operation of low temperature environment;
- Long service life: Over 75% capacity reserved after 5 years or ten thousand hours.
- Maintenance free: the battery does not need manual maintenance and does not need to add distilled water electrolyte;
- Green and clean: no pollution and zero emission.