

BASIC



WS15H-B Electric Pedestrian Stacker

Lifting height: 2000-4000 mm / Load capacity: 1500 kg



Intelligent & Efficient



Rugged & Durable



Easy & Comfortable

STAX 

EFFICIENT
COMFORTABLE
DURABLE



WS15H-B



WS15H

CONFIGURATION

BASIC

PREMIUM

Capacity



1500kg

1500kg

Lift height



2000-4000mm

2000-4000mm

Battery



● 24/71Ah ○ 24/89Ah

● 24/71Ah ○ 24/89Ah

Lift speed

(with/without load)



72 / 115 mm/s

0-102 / 0-190 mm/s

Lowering speed

(with/without load)



133 / 116 mm/s

30-135 / 20-200 mm/s

Variable speed

(LIFTING & LOWERING)



Auto slow lowering under heavy load



Lowering buffering



Safety travel speed limit



Intelligent handle



High-strength frame



C+H CHANNEL STEEL MAST
CHASSIS BASE THICKNESS 30MM

C+H CHANNEL STEEL MAST
CHASSIS BASE THICKNESS 30MM

High-strength forks



16MM SIDE PLATES
FOR MAXIMUM RIGIDITY

16MM SIDE PLATES
FOR MAXIMUM RIGIDITY

Solid supporting legs



Double-chain design



Cylinder explosion-proof valve



Battery low voltage protection



Intelligent & Efficient

Staxx patented multifunctional intelligent tiller handle is unique design for quick fault diagnosis, enabling an easier service, shorter service time and lowered labor costs.



Multifunctional intelligent tiller handle

- 1 Forward and backward control knob
- 2 Lifting & Lowering
- 3 Fault code display
- 4 Horn
- 5 Emergency reverse switch
- 6 Up-right drive and total speed



Easy Maintenance

Serial communication technology

Single wiring harness communication from tiller handle to controller system. Simple, Durable and Stable.

UART

- ✓ Low after-sales service cost
- ✓ Quick & easy fault diagnosis
- ✓ Everyone can be an expert

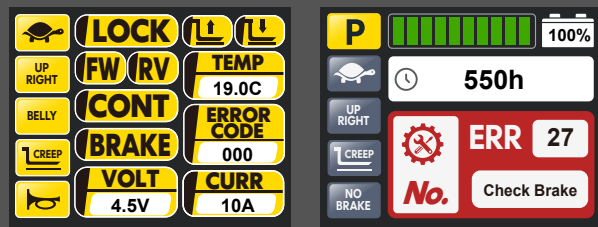

Operation status & fault diagnosis are integrated onto the tiller handle display for easy troubleshooting.

Operator Preferred

Turtle Speed — 01



Enable operator to choose different speed modes based on their experience and the specific work environment.

Up-Right Drive — 02



Easily maneuvered with the handle in the vertical position by pressing the turtle-speed button.

Engineering Mode (Brake Release) — 03



When truck is down, release the brake to move the unit manually.

Rugged & Durable

Due to a high-strength frame and mast design and solid materials used, the deformation of the frame, mast, and forks is small.



Longer service life

Mast: Standard C+H channel steel
Frame: Steel plate thickness of 5mm
Frame bottom plate: 30mm integrated steel plate

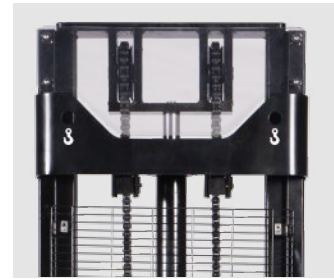

Double-chain design

Compared with single-chain design, it has higher strength, safer and more stable.

Small deformation of forks and masts, stable and durable

More stable when lifting & lowering with loads.

Full coverage protection on mast

Standard equipped with cylinder explosion-proof valve

It can prevent accidents such as uncontrolled descent caused by unexpected rupture of oil pipes, ensuring stable descent of the load and personal safety, and preventing damage to truck.

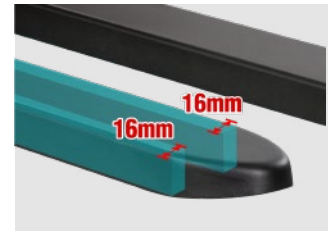

High-strength forks

16mm flat iron on both sides of fork. High strength and small deformation even under heavy loads.

Solid support legs

Increased chassis durability, higher remaining load capacity at same lifting height.

The battery is fixed at the bottom of the frame

Improved stability.

Safe operation

Emergency reverse switch

In case of an emergency, it protects the operator and the surrounding personnel from harm.

Safety travel speed limit

When the fork is lifted to above 500mm, the driving speed automatically reduces to 2km/h to ensure the safety of operating at a high position in case of any misoperation.

Built-in charger

Hidden charging plug, high safety, the whole truck is powered off during charging, reducing safety hazards.

High lateral and longitudinal stability

Wider wheelbase and longer axle distance.

The low ground clearance of 30 mm helps to reduce the risk of foot injuries

Adjustable balance wheel

Improved stability and maneuverability, suitable for different working scenarios.

Battery low voltage protection

Effectively avoid battery over-discharge, ensuring a longer battery life.



Easy & Comfortable



- **Effortless, easy to operate**
Low-mounted longer tiller reduces steering force required.

- **Low mast static height**
Easy to operate in containers and elevators with less than 3.3m lifting height.

- **The steering angle is designed to be above 180 degrees**
Small turning radius.

- **Excellent maneuverability**
Precise and maneuverable operating, high safety and efficiency.

- **Reasonable design of the balancing wheel eccentric distance**
Flexible direction commutation

- **Easy to recharge**
Built-in charger and an external charging cable storage box for convenient charging.

- **Longer operating time**
Standard 24V/71Ah maintenance-free lead-acid battery, with the option of a larger capacity maintenance-free battery or a lithium battery.



Optional Configuration

- **Intelligent control**

Unique in the market and very suitable for sorting operations on trucks. With a dedicated remote control device, the operator can control the forks to lift to the appropriate working height and carry out sorting operations, thus avoiding the need to use the handle buttons and bend over to pick up goods, improving operational efficiency and comfort.

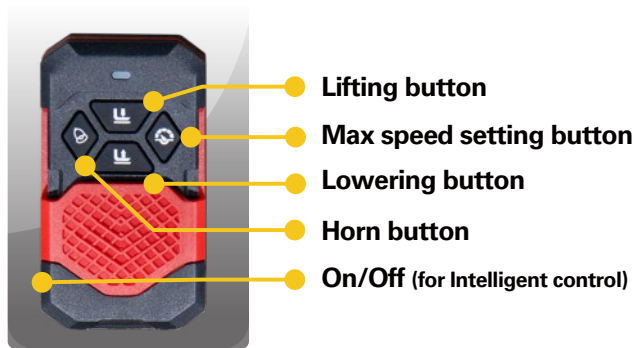

With the remote control device, you can easily set the speed suitable for the work, from level 1 speed to level 5 speed. Such speed transitions allow you to move the truck with controlled operation at ease.

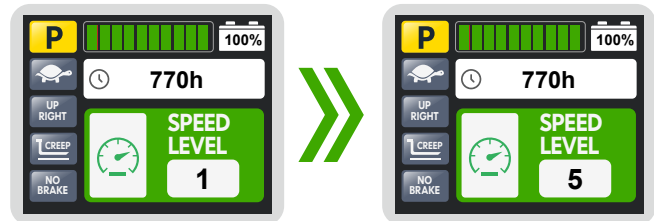

- **Reversing buzzer**

- **24V 60Ah(100Ah) LiFePO₄ Lithium battery**

- **24V/30A chargers**
Lithium Battery Charger
Charging time: 2~4 hours



Dimensions

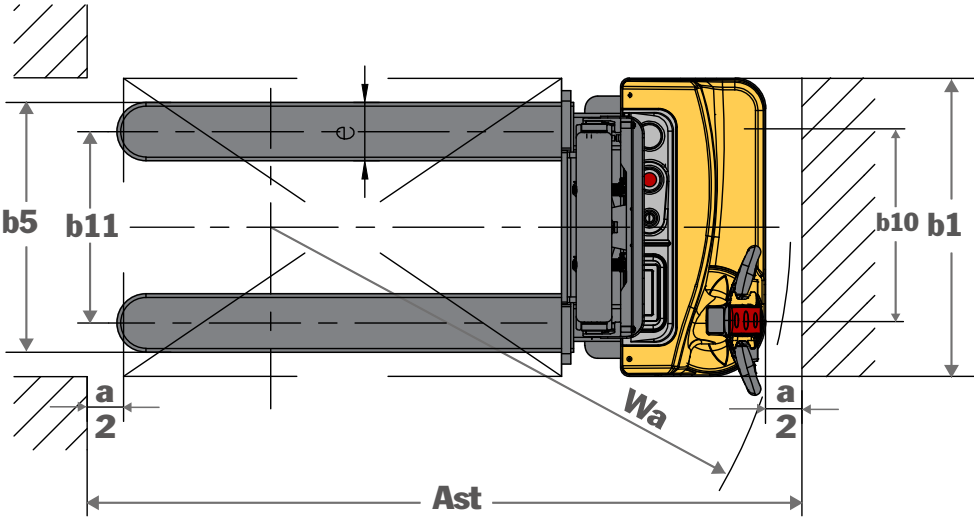
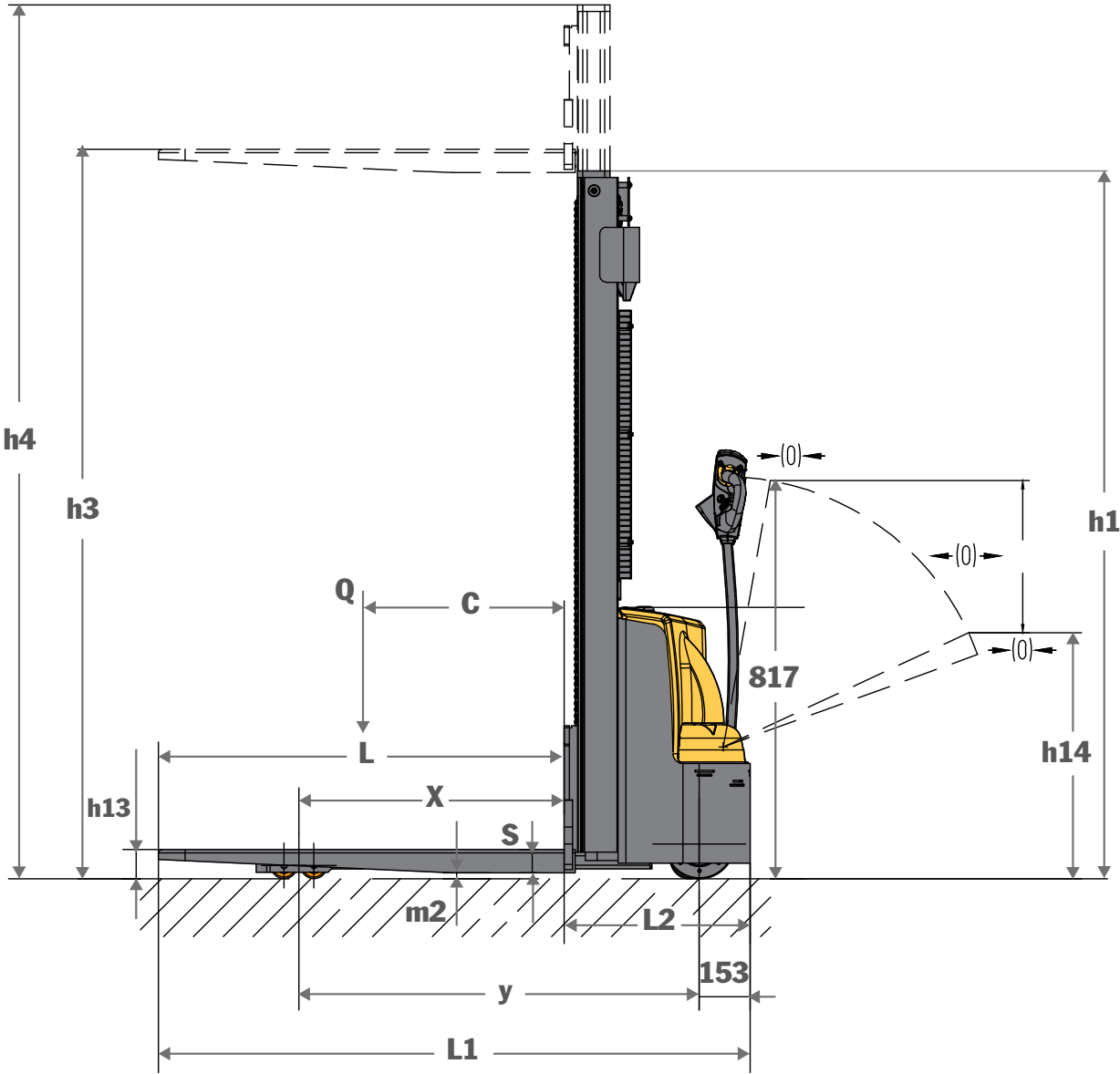

Specifications

MODEL				WS15H-B					
DISTINGUISHING MARKS									
1.3	Drive								Battery
1.4	Operator type								Pedestrian
1.5	Load capacity/rated load	Q	kg						1500
1.6	Load centre distance	c	mm						500
1.8	Load distance, centre of drive axle to fork	x	mm						796
1.9	Wheelbase	y	mm						1210
WEIGHT									
2.1	Service weight (without battery)		kg	509	529	556	565	575	612
2.2	Service weight (with 71Ah battery)		kg	557	577	604	613	623	660
2.3	Service weight (with 89Ah battery)		kg	562	682	609	618	628	665
2.4	Axle loading, laden front/rear		kg	618/1441					
2.5	Axle loading, unladen front/rear		kg	419/140					
TYRES/ CHASSIS									
3.1	Wheels								Polyurethane
3.2	Wheel size, front	Ø x width	mm						Ø210x70
3.3	Wheel size, rear	Ø x width	mm						Ø80X70
3.4	Additional wheels (dimensions)	Ø x width	mm						Ø115X55
3.5	Wheels, number front/rear (x = driven wheels)								1x + 1 / 4
3.6	Tread, front	b10	mm						550
3.7	Tread, rear	b11	mm						390(560 fork width)/525(680 fork width)
DIMENSIONS									
4.2	Lowered mast height	h1	mm	1480	1730	1980	2130	2230	2550
4.4	Lift height	h3	mm	2000	2500	3000	3300	3500	4000
4.5	Extended mast height	h4	mm	2435	2935	3435	3735	3935	4370
4.9	Height of tiller in driving position, min./max.	h14	mm	910/1270					
4.15	Height, lowered	h13	mm	85±2					
4.19	Overall length	l1	mm	1730/1800					
4.20	Length to face of forks	l2	mm	580					
4.21	Overall width	b1	mm	820					
4.22	Fork dimensions	s/e/l	mm	70x160x1150					
4.25	Width over forks	b5	mm	560/680					
4.32	Ground clearance, centre of wheelbase	m2	mm	30					
4.34.1	Aisle width for pallets 1000 × 1200 crossways	Ast	mm	2268					
4.34.2	Aisle width for pallets 800 × 1200 lengthways	Ast	mm	2194					
4.35	Turning radius	Wa	mm	1425					
PERFORMANCE DATA									
5.1	Travel speed, with/without load		km/h	4/4.5					
5.2	Lift speed, with/without load		mm/s	72 / 115					
5.3	Lowering speed, with/without load		mm/s	133 / 116					
5.8	Max. gradeability, with/without load		%	5/10					
5.10	Service brake			Electromagnetic					
ELECTRIC-ENGINE									
6.1	Drive motor rating S2 60 min		kW	0.75					
6.2	Lift motor rating at S3 15%		kW	2.2					
6.4	Battery voltage/nominal capacity (C5)		V/Ah	● 12/71 x 2 ○ (12/89) x 2					
6.5	Battery weight +/- 5%		kg	● 23.2 x 2(71Ah)/ ○ 25.8 x 2(89Ah)					
6.6	Energy consumption according to EN 16796		kWh	0.42					
ADDITION DATA									
8.1	Type of drive control			DC speed control					
8.4	Sound level at the driver's ear according to EN 12053		dB(A)	<75					
8.5	Controller			STAXX A6101					

Note: 1kgs=2.2lbs, 25.4mm=1inch

● standard ○ option

MAST DIMENSIONS							
WS15H-B				Duplex Mast			
h1	Lowered mast height	mm	1480	1730	1980	2130	2550
h3	Lift height	mm	2000	2500	3000	3300	4000
h4	Extended mast height	mm	2435	2935	3435	3735	4370

LOAD CHART

